

# 4M 'PUSH AROUND' ELECTRIC SCISSOR LIFTS

Platform	SWL Working Height Platform Floor Height	240kg 5.90m 3.90m
Dimensions	Overall Length x Width Overall Height Platform Size Ground Clearance Wheelbase	1.15m x 0.76m 1.86m 1.15m x 0.60m 0.06m 0.94m
Power	Lifting Motor Batteries Integrated Charger	12V / 0.8kw 12V/120Ah 12V/12A
Tyres		0.15m
Mass	Total Weight	420kg

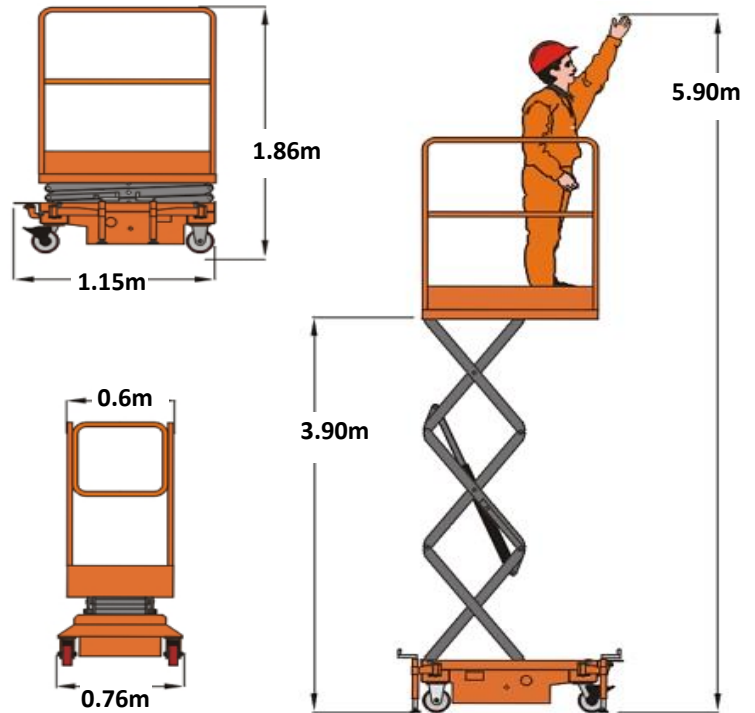

*Push it around*

*Goes through doorways and in lifts*

*Has forklift pockets*

**Dingli Rizer SP039-e**

# 6M SELF DRIVE ELECTRIC SCISSOR LIFTS

Platform	SWL SWL on Extension Max No. Workers	230kg 113kg 2 (1 on extn)
Height	Working Height Platform Floor Height	7.8m 5.8m
Dimensions	Overall Length x Width Height (Rails UP) Height (Rails DOWN) Platform Size Platform Extn Size	1.86m x 0.76m 2.16m 1.84m 1.67m x 0.74m 0.9m
Weight	Total Weight	1,400kg
Other	Ground Clearance (STOWED/RAISED) Wheelbase Tyres Turning Radius (INSIDE/OUTSIDE) Max Working Slope Gradeability Wind Rated	0.09m / 0.019m 1.38m Ø 305 x 100mm 0m / 1.64m 2 - 3° 25% 0-12.5m/s

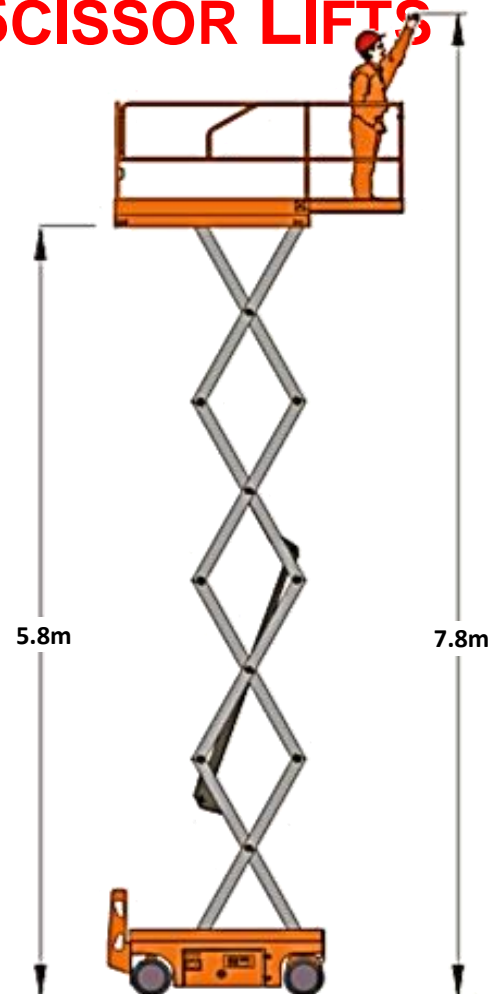

*Rails fold to reduce height*

*Fork lift pockets*

*Drive at full height*

*Horn & flashing light*

**Dingli E-Tech S06-e**

